

RD-300

SMALL AREA CAST IRON ROOF DRAIN

Small body epoxy coated cast iron roof drain with flashing clamp with integral gravel stop, self-locking polyethylene dome and no hub (standard) outlet.

FEATURES

- Engineered with cast iron for long life and durability
- Self-locking polyethylene dome (standard) and no hub (standard) outlet simplify installation and maintenance
- Flashing clamp and integral gravel stop ensure reliable drainage
- Available in 2", 3" and 4"

OPTIONS

- Push-on or threaded outlets
- Sump receiver
- Underdeck clamp
- Side outlet
- Adjustable extension flange
- PVC body

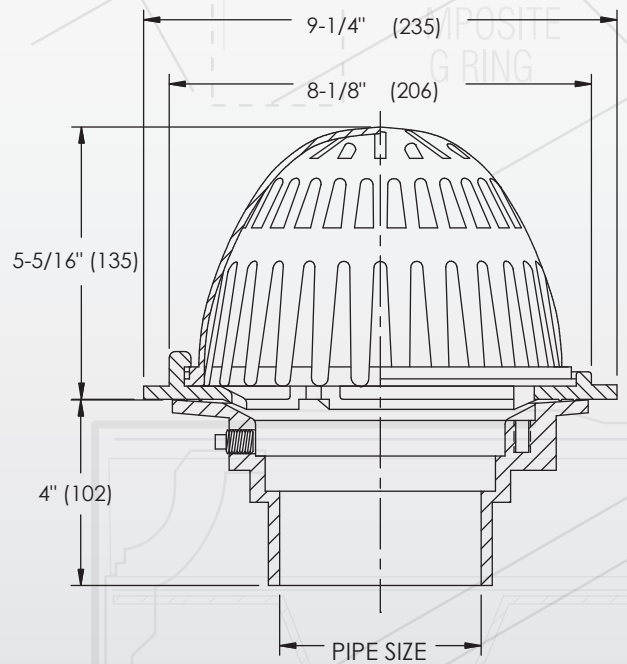

Free Area
Sq. In.
35

Deck opening 6-1/2" (165)
with sump receiver 8" (203)

Chart B

	Std.	P	T	X	60/61
Pipe Size	No Hub	Push On	Female Thread	Inside Caulk	PVC/ABS
2"(51)	3-5/8"(92)	4-1/4"(108)	4-1/4"(108)	4-1/4"(108)	3-3/4"(95)
3"(76)	3-5/8"(92)	4-1/4"(108)	4-1/4"(108)	4-1/4"(108)	3-5/8"(92)
	3-5/8"(92)		4-1/4"(108)	4-1/4"(108)	3-7/8"(94)