

# RD-260

## ONE PIECE DUAL OVERFLOW CAST IRON ROOF DRAIN

RD-260 combination roof drain/overflow with epoxy coated cast iron drain bodies, flashing clamps with integral gravel guards, 4 in. (102mm) high internal standpipe, self locking polyethylene domes, and no hub (standard) outlets.

### FEATURES

- Engineered with cast iron for long life and durability
- Self-locking polyethylene dome and no hub (standard) outlet simplify installation and maintenance
- Flashing clamps with integral gravel guards and standpipe help ensure reliable drainage and overflow
- Available in 2" 3" and 4"

### OPTIONS

- Push on
- Threaded outlet
- Aluminum strainer
- Cast iron strainer
- Vandal proof strainer
- Underdeck clamp
- Galvanized body & flashing clamp
- Side outlet

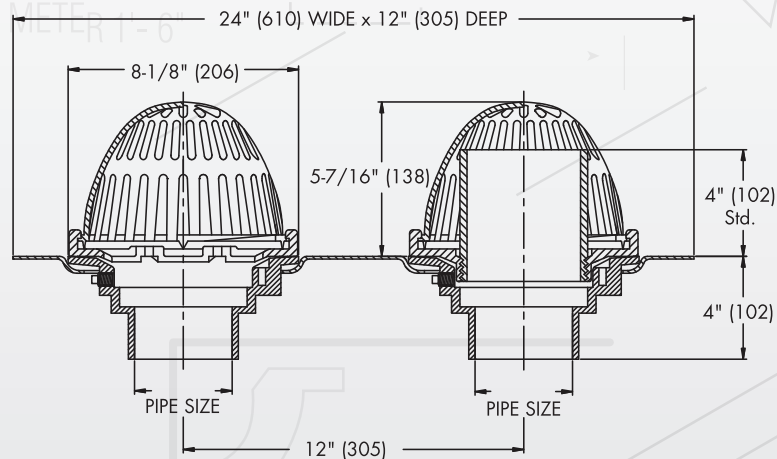

Free Area Sq. In.	<b>Deck opening</b>
70	<b>8-1/4" X 20-1/4" (210x514)</b>