

### Family, Friends, and Future...

The Marathon Companies, with a legacy spanning over six decades, stand as a testament to enduring family values that form the bedrock of the organization. The familial values, beliefs, and principles has permeated various facets of the company, with key family members assuming crucial roles. President Tod Cislo has entrusted family members with the day-to-day operations, with Jake Cislo overseeing the MRP Supports division and Amanda Cislo managing logistics operations. Christian Fachko, Amanda's husband, serves as a prominent lead sales representative. Tina, Tod's wife, heads the Board of Directors committee. The Cislo & Fachko family, deeply ingrained in the company's culture, not only guides the present but also shapes the future, extending their shared values throughout the organization.



**UPCOMING EVENTS:** Feb 6-8, 2024: IRE Show – Debuting our NEW Island Booth!



## When it Rains...Marathon Shines!

**<<< Scan to View our NEW Product Line Card!**





# FEATURED PRODUCTS: POSEIDON STAINLESS STEEL

The Poseidon stainless steel roof drains, protect your home from salty ocean air and combat coastal conditions.

- Optional PVC or TPO coating for direct hot weld applications
- Available in sizes 3"-6"
- Poseidon Adjustable Drain Guards Available

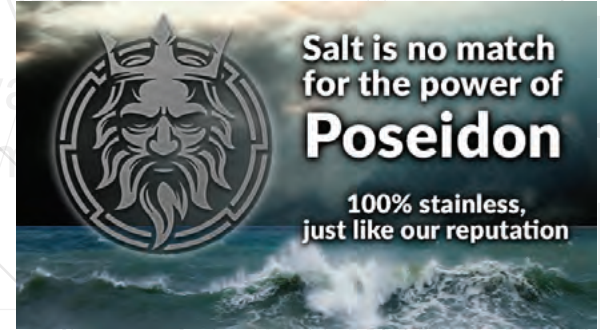

## THE ACCOUNTING DEPARTMENT KEEPING FAMILY TOGETHER

Ann Mitchell and Roberta Brown lead the Accounting Department at Marathon Companies. Tyler Mitchell, who is Ann's son, has been part of the warehouse staff for over three years, gaining valuable manufacturing experience while pursuing his studies at RIT. Ron, Roberta's significant other, recently joined our warehouse staff in December. Ron's main responsibilities involve special coatings and soldering the roof drains. These family connections contribute to the ongoing development of trust and collaboration on a daily basis.



We have all of our products available in high-quality design files! Our partnership with CADdetails allows you to see which products are an exact fit for your next project!

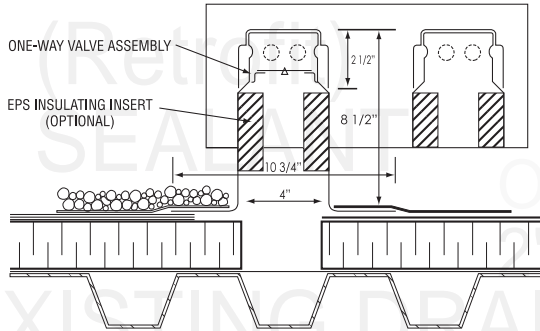

## EMPLOYEE SPOTLIGHT: THE WAREHOUSE STAFF AKA THE GOON SQUAD

The warehouse of the Marathon Companies is tied together through strong lifelong friendships. Wes, John, David, Josh & John have all attended Orchard Park High School together. They work extensively between Marathon Roofing Products & MRP Supports on the daily basis to make sure our inventory gets to every customer in a timely manner.

Matt, Rick & John have been friends for over 20 years. The originals started working at Abbott Pizza, then K-Mart Supermarket store. Still aligned they are here with Marathon Companies in assisting the day-to-day operations in the warehouse.

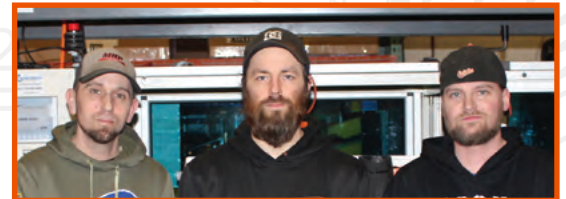

Follow us!



/marathondrains



@marathoncompanies



marathon-roofing-products



@marathonmrp